

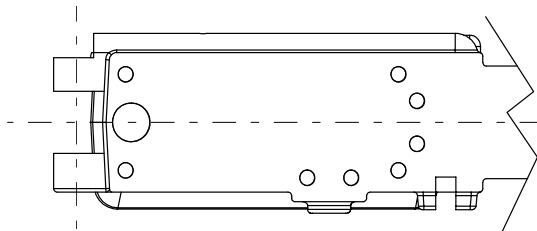

Next, put the 5/16" diameter hole through at the location shown below. This hole creates the little arc in the front of the mag well for clearance for the magazine rivits. This cut will leave a finished surface so feed lightly, use cutting fluid and clear the chips often. If you have a 5/16" reamer, then finish the hole with it.

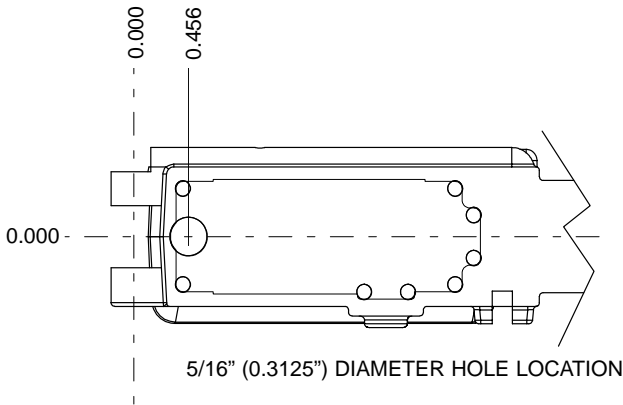

*The forging will look like this after the 5/16" hole is drilled.*