

Spot and drill the four roughing holes through with a 5/16" or 3/8" drill. Next, drill through 1/2" diameter at the same locations.

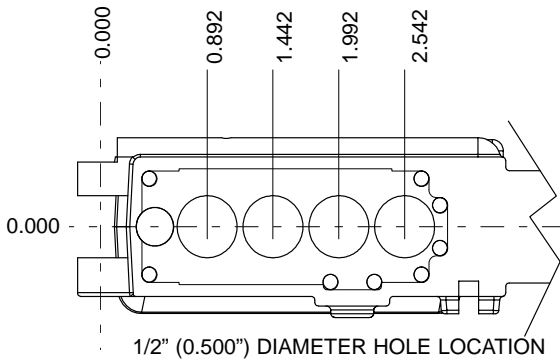

*The forging will look like this after the 1/2" holes are drilled.*

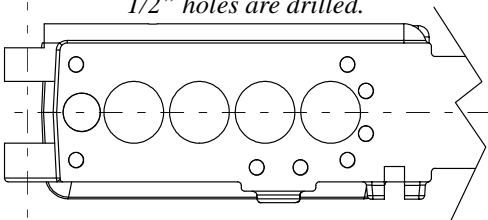

*Don't forget to inspect before moving on to the next operation.*